

Cubetape

Mobile Dimensioning and Scanning



An introduction to a better
Dimensioning Solution



Cubetape

Things to Discuss



Contents:

- Protecting your bottom-line
- Dimensioning, current state
- A better way exists
- Cubetape - the device
- Why Cubetape?
- Device specifications
- Who is it for?
- How does it work?
- Powerful software for complete solution
- Cubetape + Quanta in action
- Investment
- Also from Cubetape



Cubetape

Protecting Your Bottom Line



	DESCRIPTION
	PLASTIC BOTTLE, 10-12# PCF 1FKF 1010020410 ILC 04240
	082 CLASSIFICATION CHANGE UPDATE PER INSPECTION 0040 CURIC FEET
	** FAK RATES APPLIED **
	001670 FUEL SURCHG LTL SHPT13.50%
	819 LESS DISCOUNT
	000013203 ORIGINAL REVENUE
	80710-83083083083
	8.8' PCF
	DIMENSION-DENSITY INSPECTION SEE DIMS CERTIFICATE FOR DETAILS SECTION / SIGNED
	NWB INSPECTING TERMINAL

Protect yourself from and reduce the impact of reclasses, reweighs, and other invoice surprises.

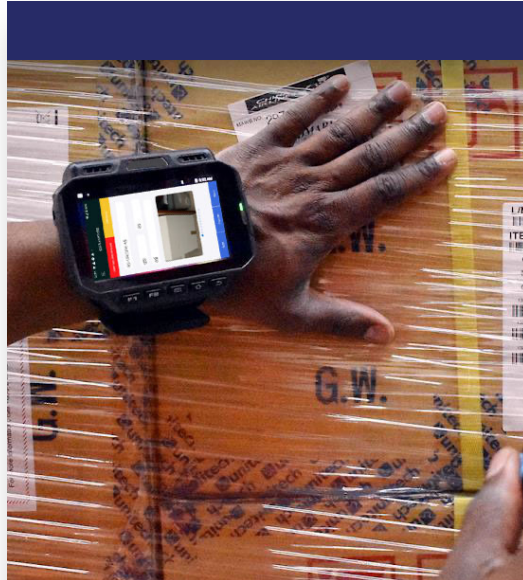

Build and maintain a SKUmaster database of your products.

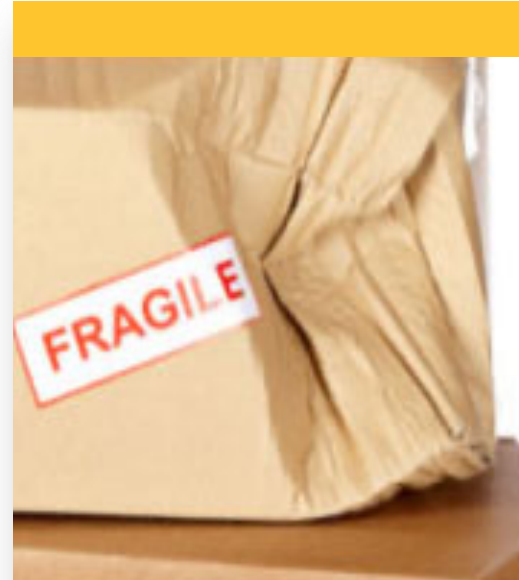

Mitigate/eliminate the impact from loss and damage claims.



Prevent and defend retail chargebacks.

Dimensioning Solutions

Current State of Affairs



Low Cost, Risky Option

Regular tape measure,
pen, paper, and memory



Complicated, Costly Option

Static Dimensioner
Parcel = \$4,000 - \$7,000
Pallet = \$25,000 - \$60,000
IT Department Integration

Historically, companies have had 2 options for dimensioning their parcels and pallets.

On one hand, a tape measure with pen and paper or memory. On the other hand, very expensive static dimensioners.

Presenting a Better Option...

The Cubetape Suite of Solutions



Low Cost, Risky Option

Regular tape measure,
pen, paper, and memory



Complicated, Costly Option

Static Dimensioner
Parcel = \$4,000 - \$7,000
Pallet = \$25,000 - \$60,000
IT Department Integration



- ✓ Cubetape Device
- ✓ Quanta Software
- ✓ Simple Integration
- ✓ No IT Team required

Cubetape

Much More than a Tape Measure



Cubetape allows you to capture shipment dimensions and ref numbers, and transmit them via Bluetooth to your system.

It integrates seamlessly with a handheld device or workstation via Bluetooth as it emulates keyboard (manual entry) commands. Use the Quanta mobile app to add photos, weight, and notes, and store the data in the cloud database.



Tape Measure:
5m and 7.5m length options



Modular Design:
Components easily replaceable



Barcode Scanner:
1D and 2D barcodes



Rugged Device:
Readily handles rigors of a freight environment



Data Collector:
1-3 barcodes and 3 dims - L x W x H



Patented Product:
Protected by US Patent 11,156, 445



Data Transmitter:
Bluetooth-enabled



Handheld App:
Captures barcodes, dims, weight, photos, notes

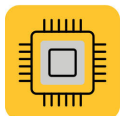

Micro-Processor:
Reads and interprets barcode commands

Cubetape

Why?



Measures up to 7.5m in length:

Uses patented Barcode on Tape (BoT) technology for accurate measurements.



Mobile and portable:

Measure them where they are.



Built-in barcode scanner:

Saves time and improves productivity.



Mitigate human error:

Eliminates transposition and data entry errors (faulty memory).

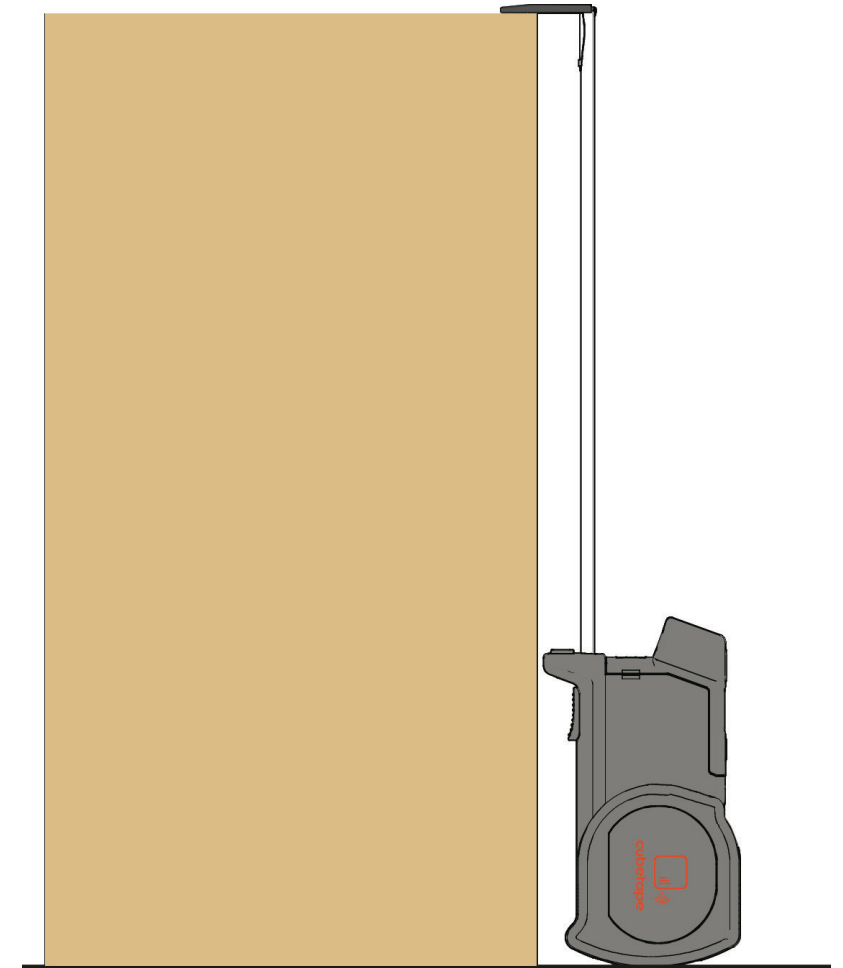

Cubetape

Why?



Seamless integration with your system:

Integrates with any hardware device, and any software application.



Suite of solutions for all dimensioning needs:

Includes a wide range of configuration options and accessories.



Adheres to trade regulations:

Certified for use in legal for trade applications in major markets.



Won't break the bank:

Cost effective to purchase, use, and integrate with your existing systems.

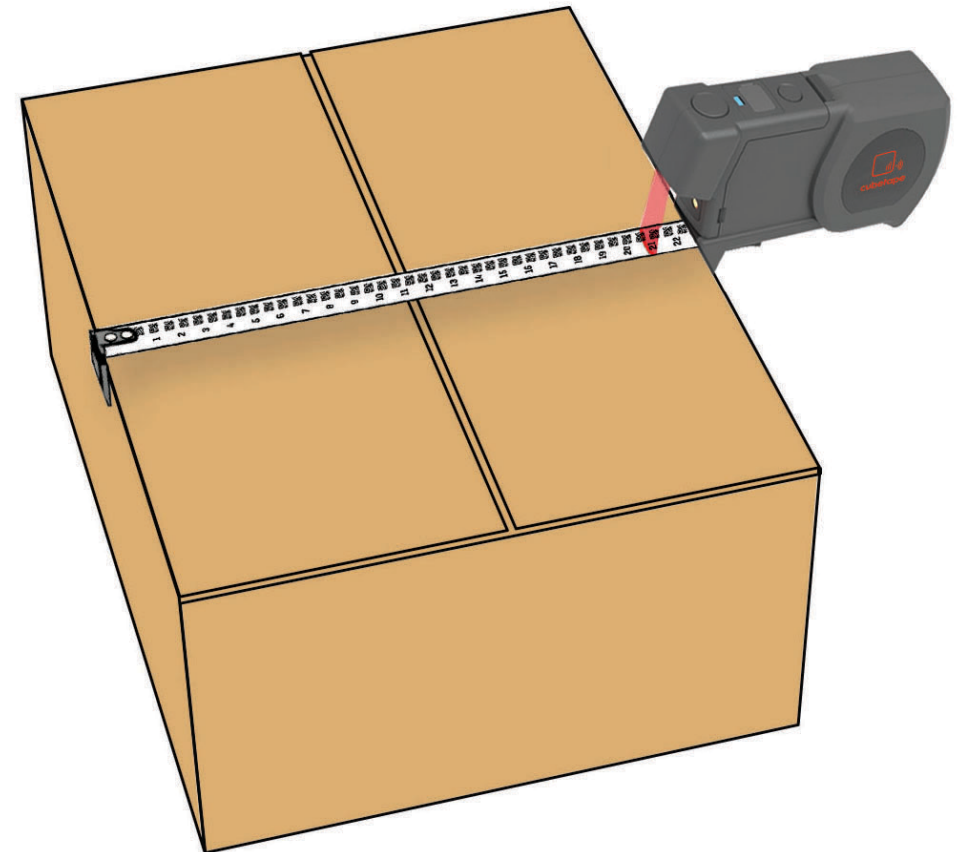

Cubetape

Device Specifications



Size/Weight:
5m – 400g
7.5m – 510g



Working Temperature:
-30°C – 70°C



Battery Life:
8 hours



Tape:
Barcode on top



Recharge Time:
2 hours



Markings:
Standard on bottom

Cubetape

Who Is It For?



- LTL Shippers
- LTL Carriers
- Parcel Shippers
- Parcel Carriers
- Warehouses
- Freight Forwarders
- 3PL Companies
- Freight Tech Providers
- Logistics Providers
- Final Mile Providers
- Freight Pay/Audit
- Quality Control



Cubetape

How Does It Work?



1

Measure

Grab your handheld device powered by Quanta, and grab a Cubetape.

2

Capture

Capture your shipment data, including dimension, weight and photos.

3

Submit

Submit the captured shipment data to the Quanta Cloud.

4

View

View / share your shipment data across and outside your organisation.



Powerful Software

A Complete Solution



Quanta Handheld Application

- Feature-rich Android and iOS app
- Bluetooth, manual, and voice entries
- Supports photo capture
- 90-day data storage
- Use with any manual measuring device
- Notes can be entered manually, or dictated via voice
- Data can be exported via email

- ✓ You can use Quanta with your choice of dimensioning hardware.
- ✓ Available for download with free 30-day trial.
- ✓ Provide Quanta and Cubetape as a solution to your customers.
We'll white-label it for you!

Quanta Cloud

- Feature-rich software with intuitive search capabilities
- Full print, email and file save functionality
- Can be shared across an organisation
- 24-month data storage
- Data can be exported via email for archive
- Integrations via API available

Quanta

Works with YOUR Hardware



Quanta works with any dimensioning tool such as a standard tape measure. For best results, pair it with a Cubetape device.

- Cost effectively priced per user per month
- 30-day trial available



Cubetape + Quanta

A Winning Combination



Operator Actions

- 1** Scan Barcode
- 2** Measure Length
- 3** Measure Width
- 4** Measure Height
- 5** Takes 2 Photos

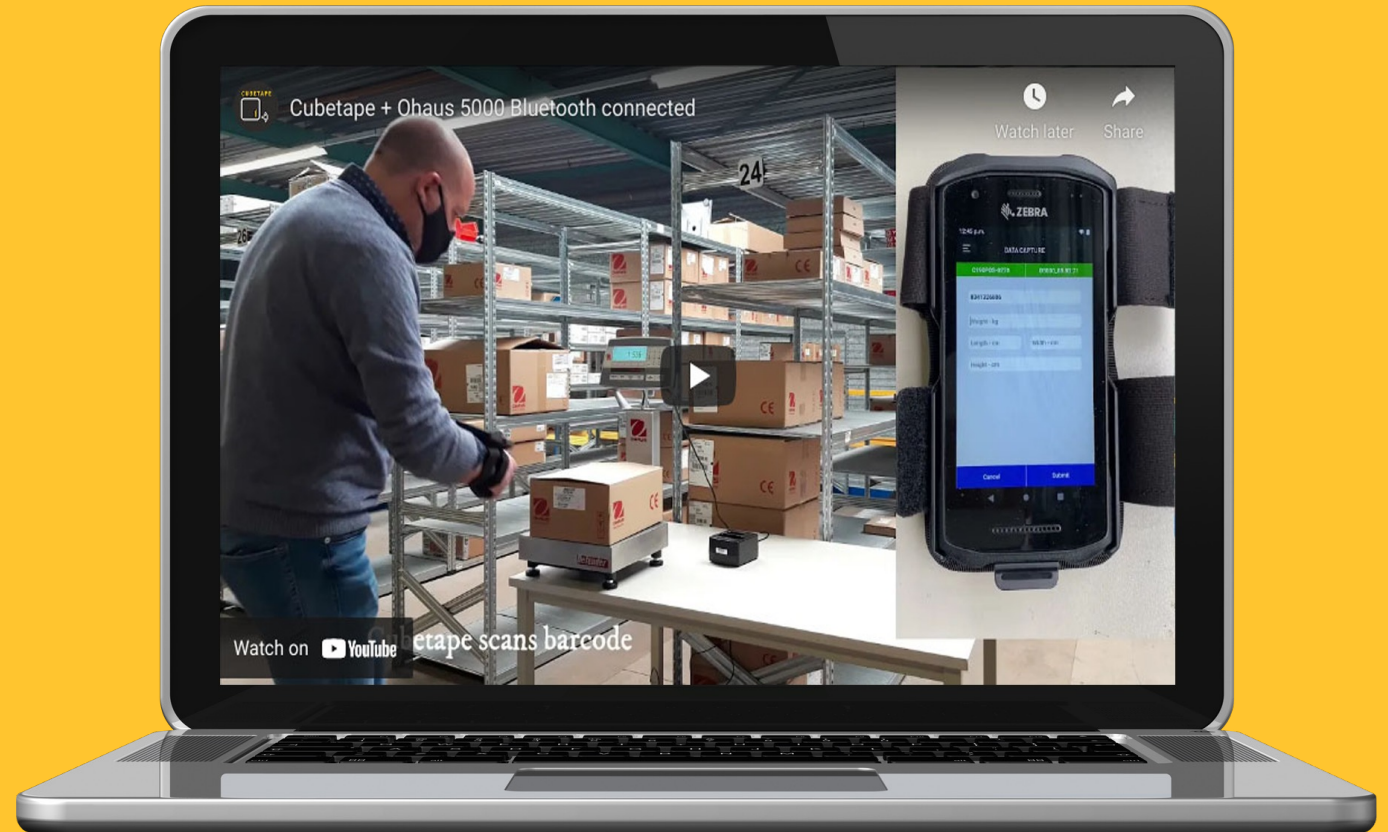

Note: Weight is passed from scale to handheld app via Bluetooth.
All data is then sent to web-based Cloud program for sharing.

Cubetape

Other Devices from Cubetape

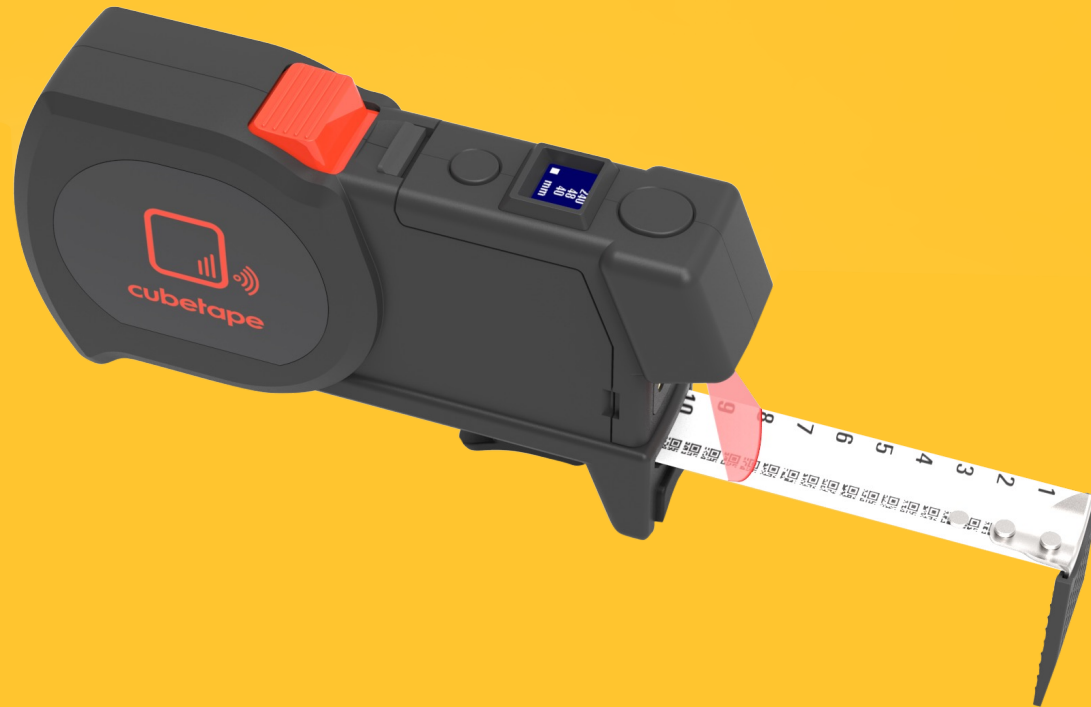

COMING IN H2 2023

C200W Wi-Fi Edition

- Wi-Fi enabled
- Eliminates Handheld

Cubetape

Mobile Dimensioning and Scanning



Contact Us

We'd love to talk about all things dimensioning and master data to improve your bottom-line.



Mobile/WhatsApp
+48-664-059-911



Email Address
piotr.klepczarek@cubetape.com



Website
<https://cubetape.com>

